



LG AIR CONDITIONER

THERMAV™

HIGH EFFICIENCY AIR TO WATER HEAT PUMP



LG Electronics
AE Company, Commercial Conditioning

Two IFC, 10 Gukjegeumyung-ro, Yeongdeungpo-gu, Seoul, 150-945, Korea.

www.lg.com www.lgeaircon.com

Copyright © 2014 LG Electronics. All rights reserved.

Distributed by



LG HVAC SOLUTION INDEX



Why LG AWHP?

04 **Why LG AWHP?**

What is THERMA V?

06 **What is THERMA V?**

THERMA V Line up

08 **2014 Model Line-up**

THERMA V Line up

10 **Various Type of THERMA V**

12 **Supreme Energy Efficiency**

16 **Reliable & Safe Heating Performance**

18 **Superior User Comfort**

Flexible Application

20 **Flexible Applications**

22 **Flexible Application / Split Type**

24 **Flexible Application / Monobloc Type**

Specification

27 **Therma V High Temperature Type**

28 **Monobloc Type**

32 **Split Indoor Unit**

33 **Split Outdoor Unit**

Domestic Hot Water Tank

36 **Domestic Hot Water Tank**

Accessory

38 **Domestic Hot Water Tank Kit**

39 **Solar Thermal Kit**

**VITALIZING
EVERY
ENVIRONMENT**

LG CAN IMPROVE YOUR QUALITY OF LIFE

In an affordable, eco-friendly way. Over the years, LG has strived to meet the demand for high quality air conditioning solutions with greater energy efficiency, which can reduce energy costs and also help to protect the environment. Greater energy savings can be achieved over the lifetime of the product which can offer cost savings to your home and business.

Furthermore, LG's air conditioners are reliable products with long lifespans designed to provide years of hassle-free performance.



Why LG AWHP?

LG THERMA V with its inverter technology is well-prepared for this regulatory change, because the energy consumption adapts itself to the heat load, that depends on the outdoor temperature by utilizing LG's superior inverter technology.



Supreme Energy Efficiency

COP up to 4.5 by Realizing all Inverter Technology



Reliable & Safe Heating Performance

Quick & Stable Performance by New Technology



Superior User Comfort

User Friendly by Providing Multiple Control Options



Flexible Applications

Solution Expansion by Flexible Comparability

WHAT IS THERMA V™

THERMA V is LG's newest Air to Water Heat Pump system, especially designed for new housing and renovation by LG's advanced heating technology with energy saving.

THERMA V can be used as various heating solution from floor heating to hot water supply with multiple heat sources.

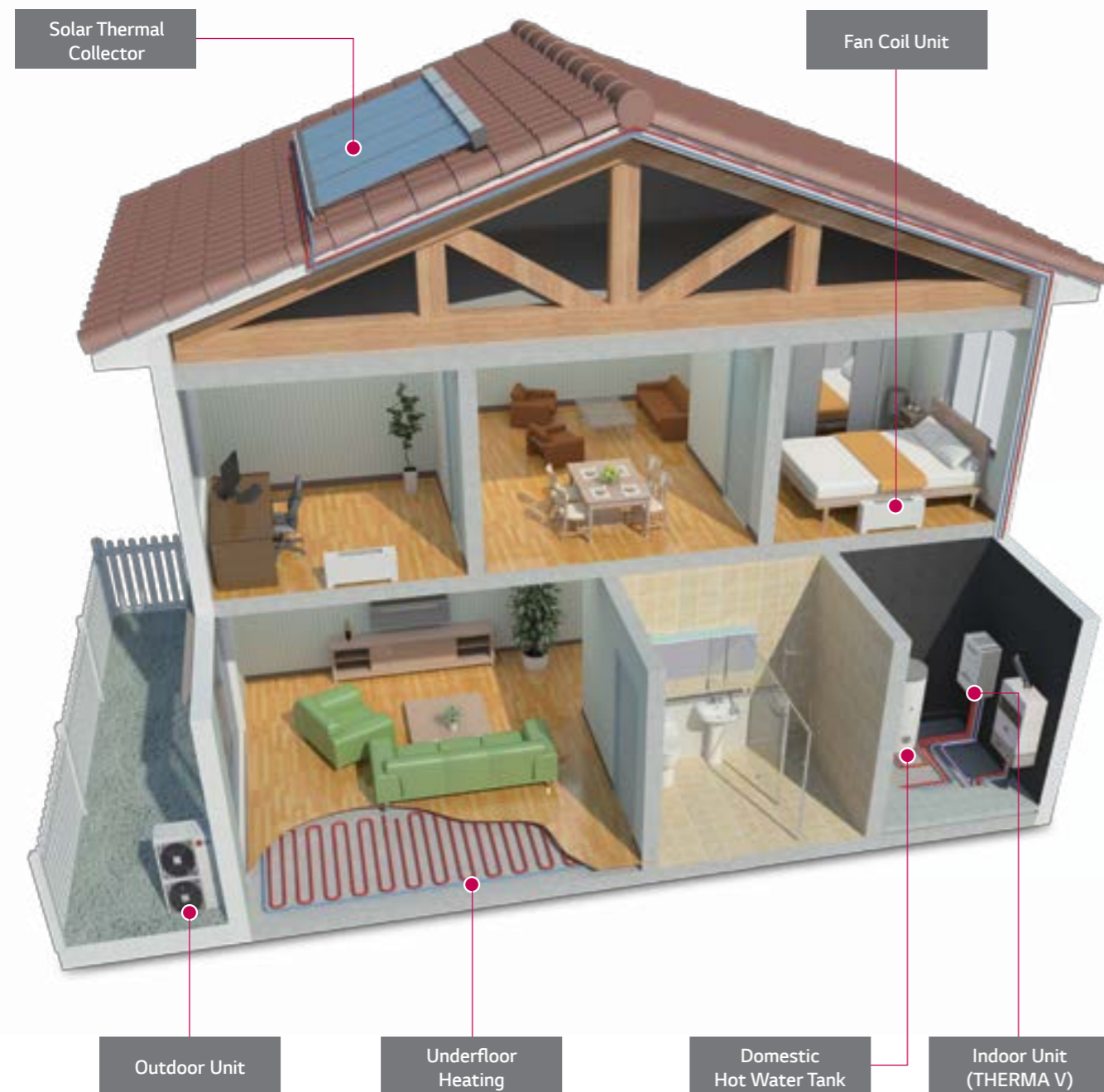

THERMA V is the Most Efficient Heating Solution for Your House.

THERMA V offers the best solution for home heating and hot water supply with LG's inverter technology. It is 4 times more energy efficient than boiler system by absorbing energy from the outdoor environment.

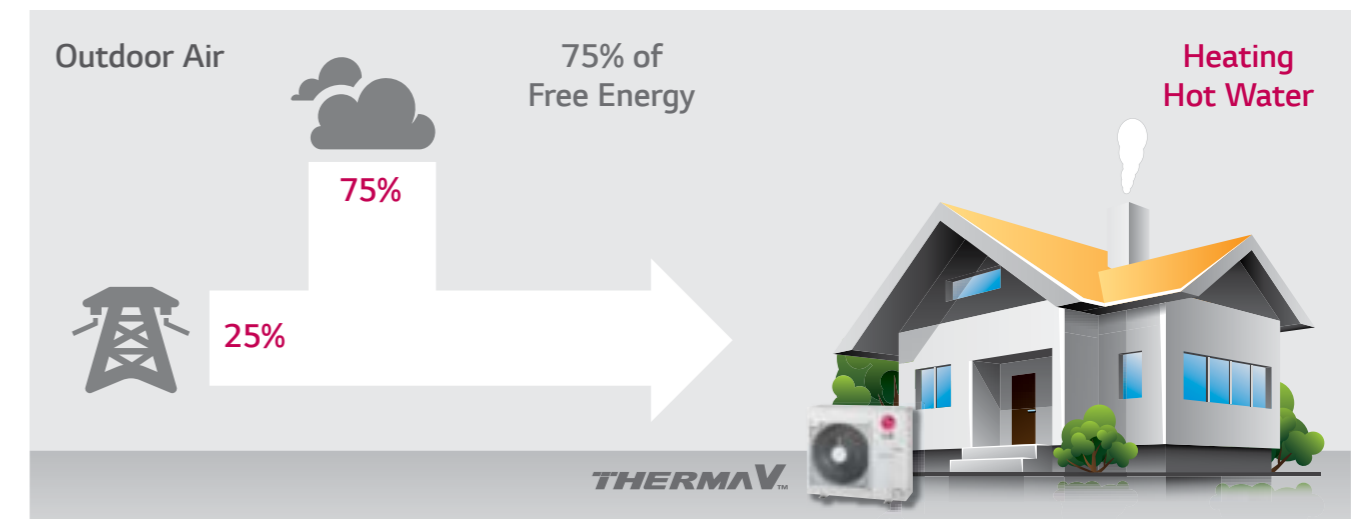

Best Solution for New Housing & Renovation

THERMA V can be the best alternative to conventional boiler system for renovation houses or as a hybrid back-up solution to the boiler.

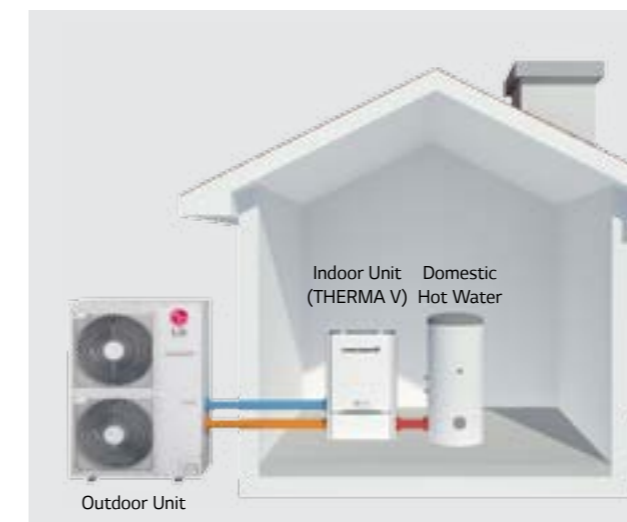

New Housing Type



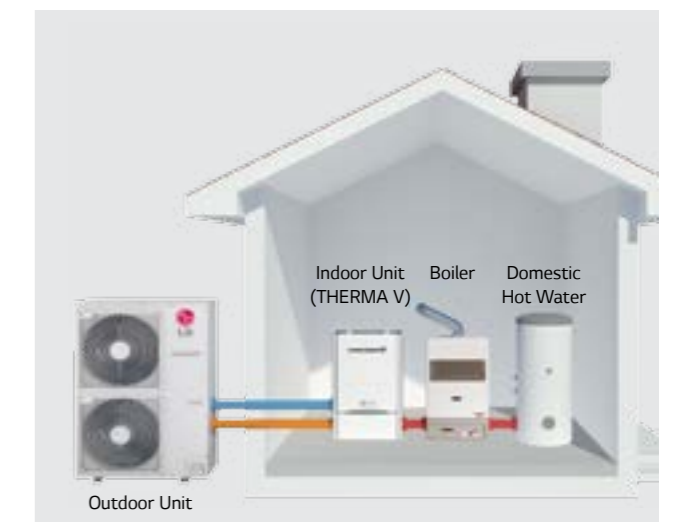





Renovation Type



2014 LINE-UP

Monobloc Type				
kW	3	5	7	9
1ø	 HM031M.U42	 HM051M.U42	 HM071M.U42	 HM091M.U42

Monobloc Type			
kW	12	14	16
1ø	 HM121M.U32	 HM141M.U32	 HM161M.U32
3ø	 HM123M.U32	 HM143M.U32	 HM163M.U32

Split Type Outdoor Unit				
kW	9	12	14	16
1ø	 HU091.U41	 HU121.U31	 HU141.U31	 HU161.U31
3ø		 HU123.U31	 HU143.U31	 HU163.U31

Split Type Indoor Unit	
1ø	 <ul style="list-style-type: none"> HN0914. NK1 HN0916. NK1 HN1616. NK1
3ø	 <ul style="list-style-type: none"> HN0926. NK1 HN0936. NK1 HN1626. NK1 HN1636. NK1 HN1629. NK1 HN1639. NK1

VARIOUS TYPE OF THERMA V

Monobloc Type



Monobloc

MONOBLOC + DOMESTIC HOT WATER + BOILER + RADIATORS + HOT WATER

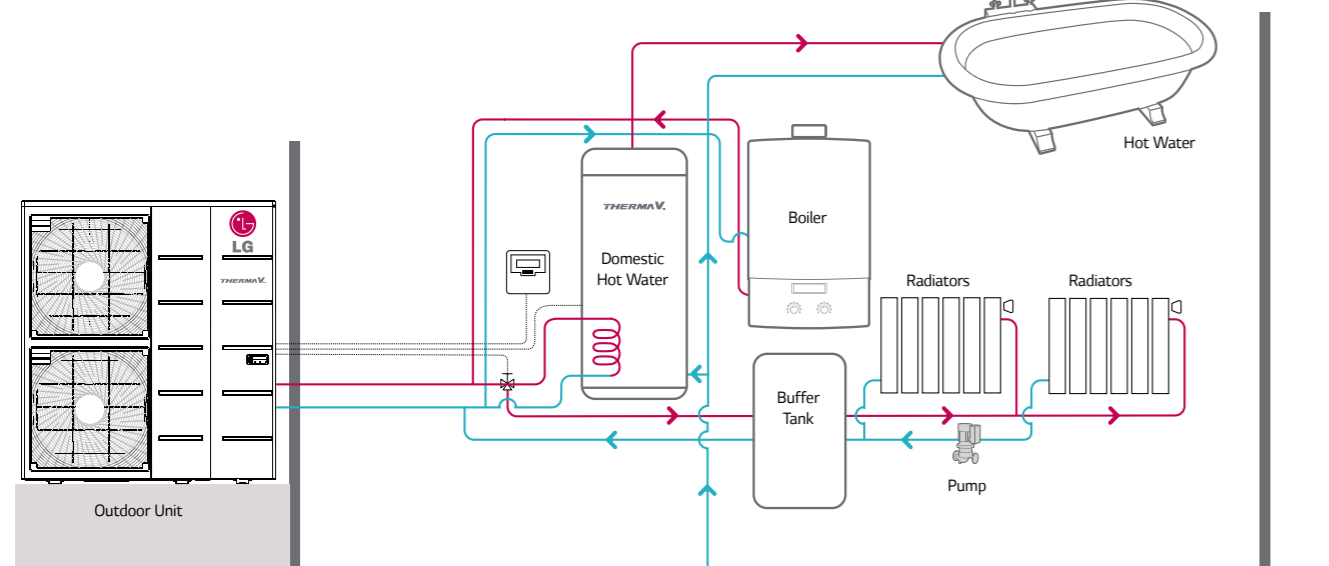

Split Type



Split

SPLIT + DOMESTIC HOT WATER + BOILER + RADIATORS + HOT WATER

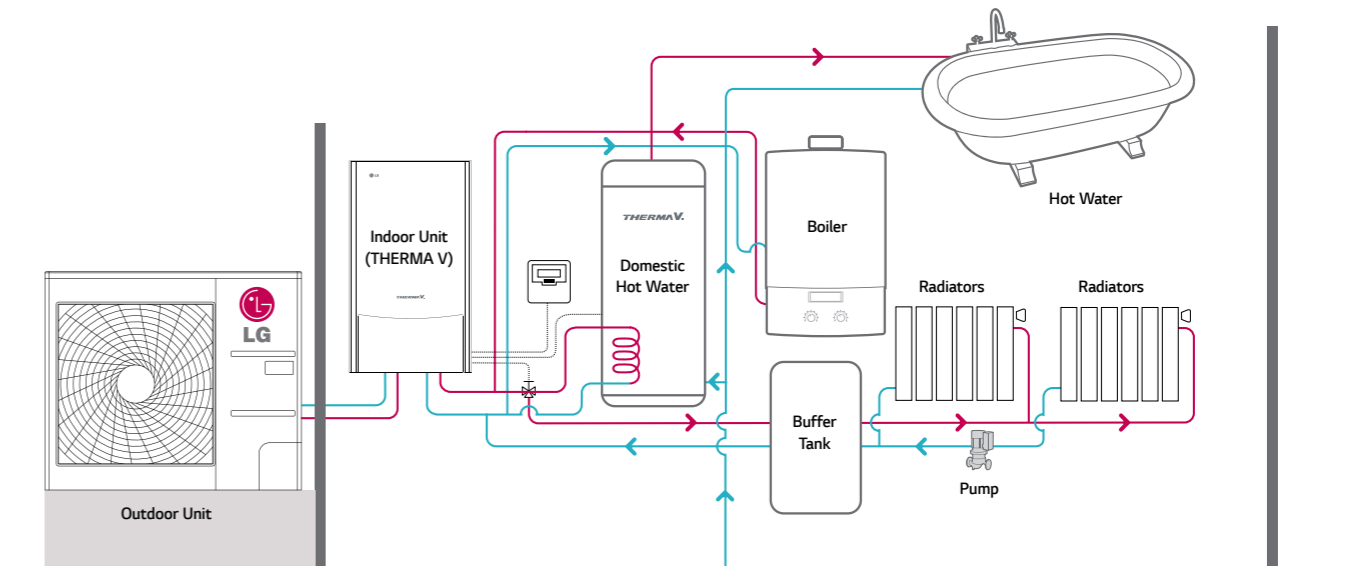

SUPREME ENERGY EFFICIENCY

Powerful, Quick Operation by PI Control

With PI control logic, the set temperature is achieved quicker and also the air conditioning efficiency is improved by 30%. It provides not only quick but also powerful air conditioning operation.

*PI: Proportional-Integral

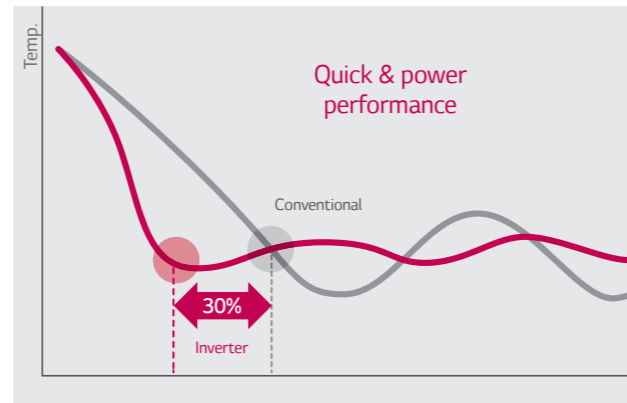

Inverter Technology

With the advancement of Inverter technology, it comes to be more silent, economical and powerful air conditioning systems. The LG air conditioner is manufactured based on the PFC and the sine wave technology. It makes possible to down noise level, be better efficiency, minimize compressor vibration and wider operation range.

Step-up Inverter by the PFC & the Sine Wave Control Technology (PFC : Power Factor Correction) compared to conventional.

PFC(Power Factor Correction) Control in Power Input

*V : Input voltage *I : Input electric current

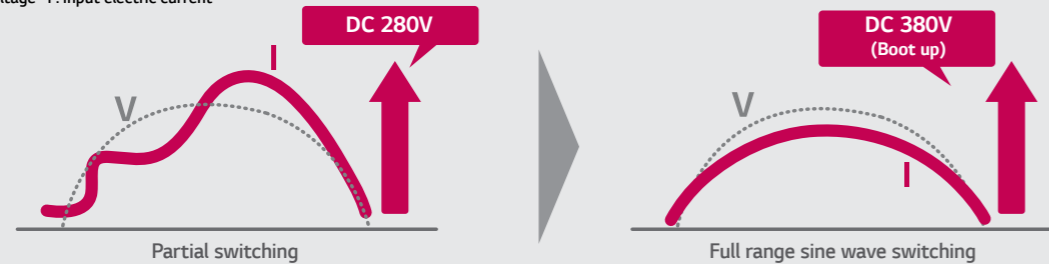

The operating voltage is increased from DC 280V to DC 380 V. This means that at high load conditions, there will be less energy consumption while at low load conditions the energy consumption.

Sine wave Control in BLDC Compressor

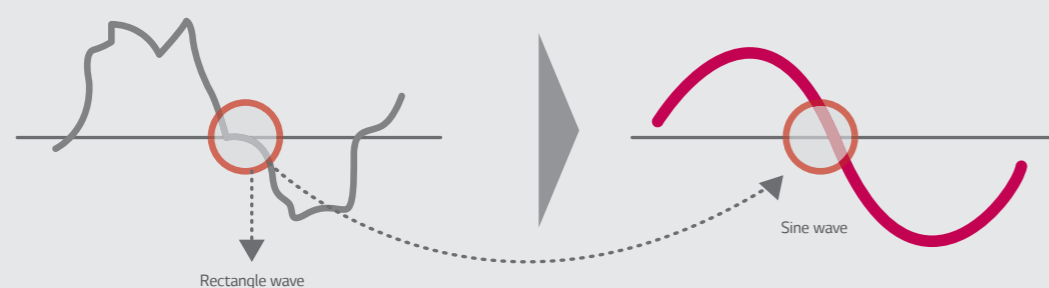

With sinusoidal wave function of the voltage, the sine wave makes the function more soft and efficient.

Powerful BLDC Compressor

THERMA V is equipped with a BLDC compressor that uses a strong neodymium magnet. The compressor has improved efficiency compared to standard AC inverter product and it is optimized for seasonal efficiency.



- Minimized oil circulation
- High efficiency motor
- Optimized compression
- Optimized vibration, noise
- High reliability

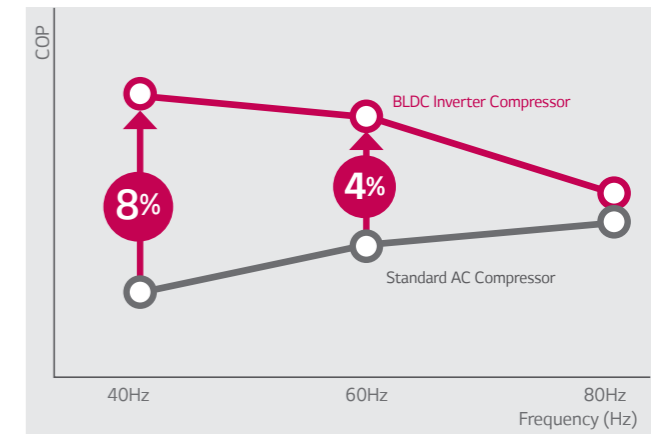

Inverter BLDC Fan Motor

The LG BLDC fan motor offers additional energy savings up to 40% at low speed and 20% at high speed compared to an AC motor.

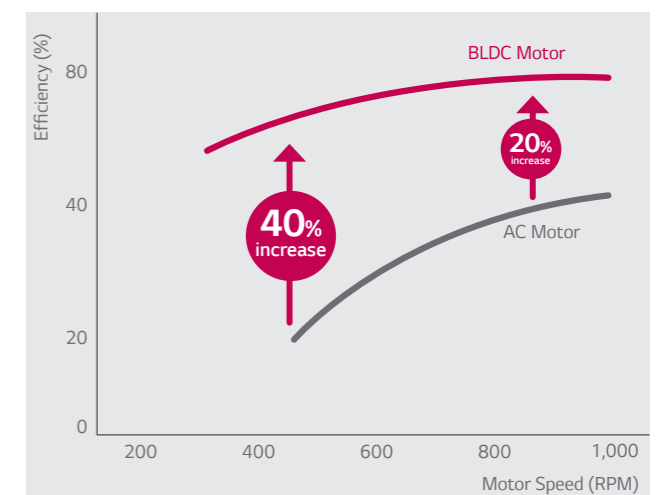

SUPREME ENERGY EFFICIENCY

Minimizing Standby Power

THERMA V can minimize power consumption by turning off PCB except for the MICOM which receives signals.

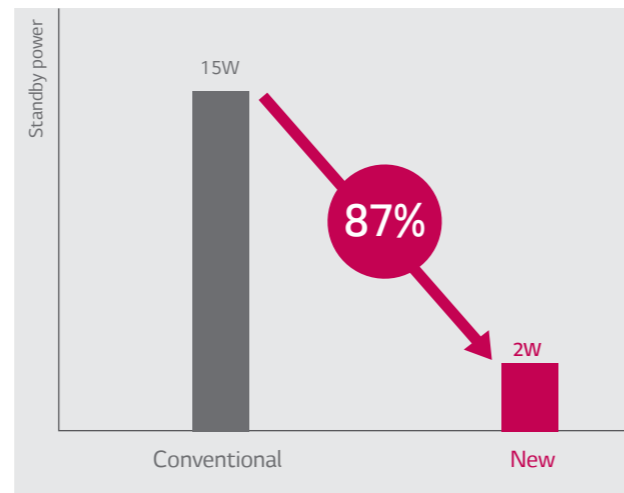

* Based on HM163M model

Heat Exchanger Improvement

Efficiency and performance are improved by increased heat exchange rate of wide louver fin & new optimal distributor design applied to the heat exchanger.

- **Wide Louver Fin**
Improved heat exchanger efficiency of up to 28%.
- **Optimized Heat Exchanger Path**
Improved cycle efficiency up to 5% with equal distribution.

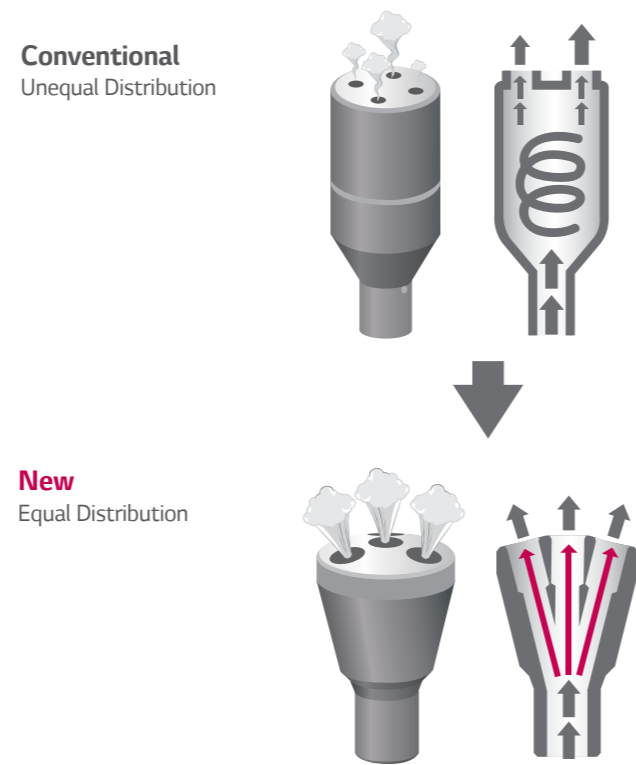
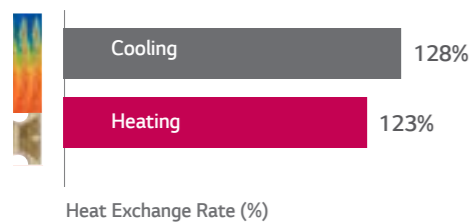

High Efficient Inverter Water Pump

THERMA V is equipped with a high efficient inverter water pump minimizes operating & standby energy during using time. (operating power input 130W → 45W)



Top Class Efficiency

LG Therma V has achieved one of the highest energy efficiency levels with BLDC inverter Compressor and optimized cycle design. The heating COP of all models are above 4.1 (1/220~240/50 Monobloc model comparison)

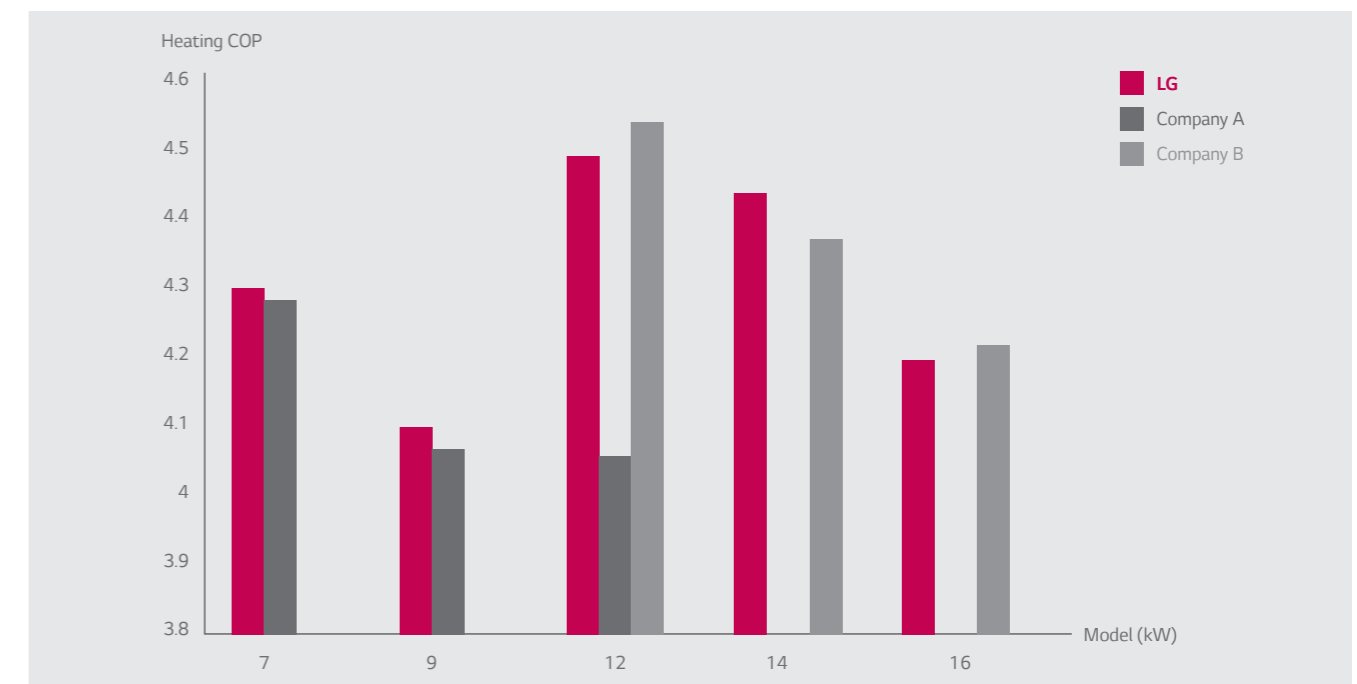

* Condition : Inlet / Outlet Water Temperature 30°C / 35°C, Outdoor Air Temperature 7°C DB / 6°C WB

RELIABLE & SAFE HEATING PERFORMANCE

High Reliability with Pressure Control

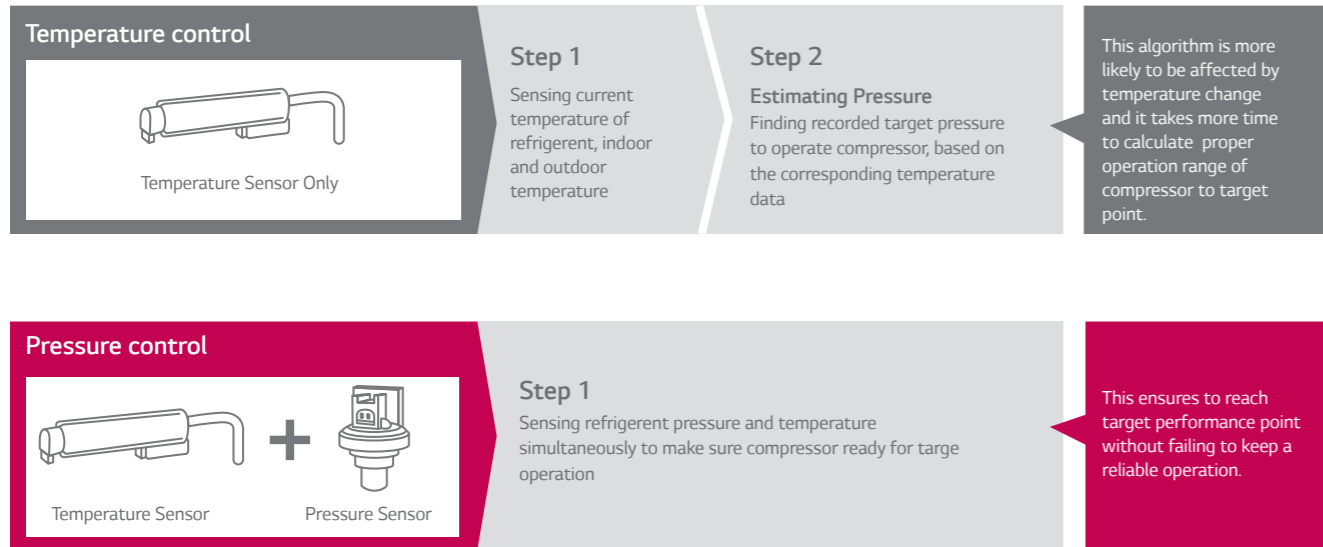

Quick Operating Response

Pressure control takes up to 44% less time to reach the desired temperature with a high level of accuracy and stability.

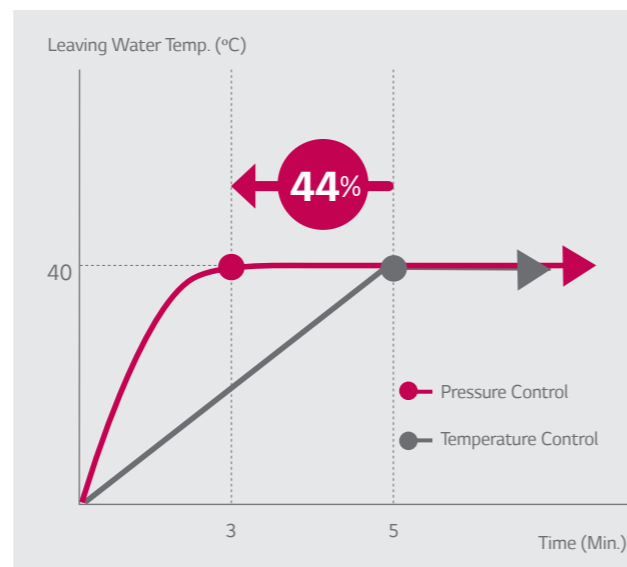

Emergency Operation

Even in case of sudden product error, THERMA V ensures stable heating operation by applying 2 steps of emergency control.

- In case of minor problem (Mainly caused by sensor)
 - Forcing to operate with setting dip switch inside unit
- In case of major problem (Mainly caused by outdoor)
 - Forcing to operate with using electric heater

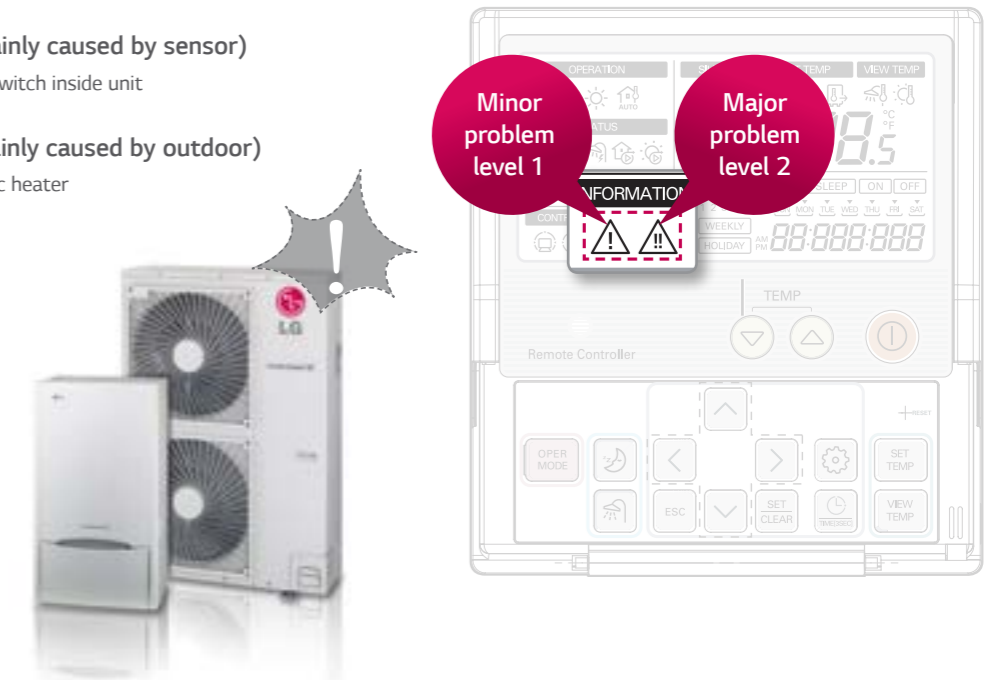

Improved Grille & Fan

The new grille shape design on the outdoor unit helps to disperse air more efficiently which improves heat exchange and reduces noise level. The new axial Fan has a thick front edge and smooth rear edge, this provides a high efficiency, low noise, wide fan, as well as improving the air flow rate.

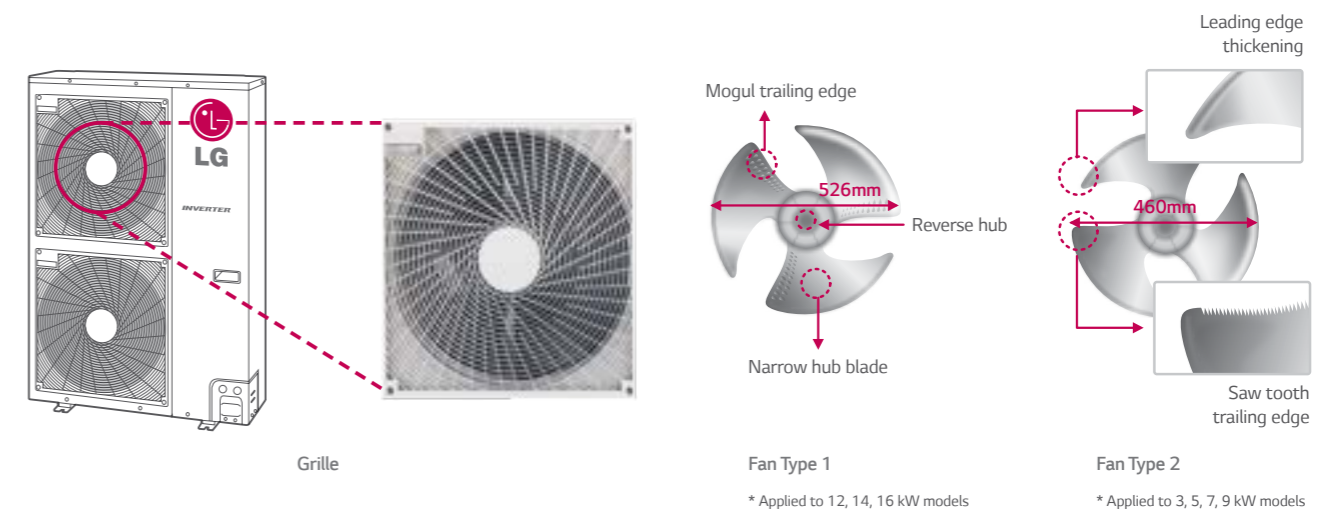

SUPERIOR USER COMFORT

Weather Dependent Operation

If users choose this mode, setting temperature will follow outdoor temperature automatically. If outdoor temperature decreases, heating capacity for the house will increase automatically in order to keep same room temperature.

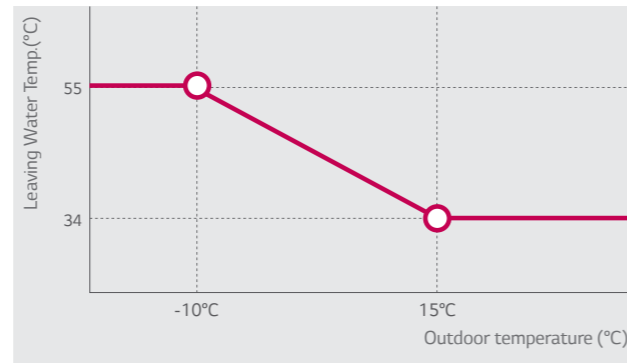

Silent Mode + Scheduler

Night Silent operation can reduce the noise level at the night time by setting dip switch on PCB of outdoor unit and set the weekly automatic on/off function.

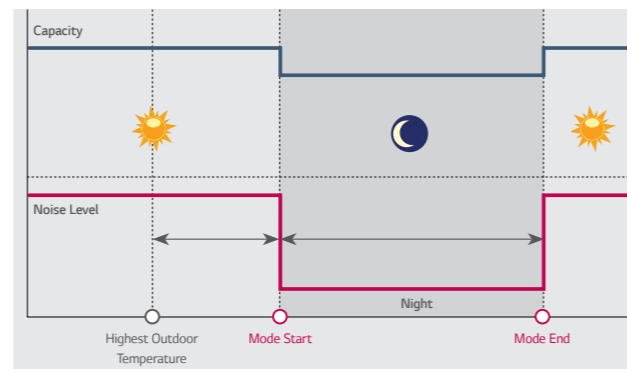

Screed Drying Program Function

THERMA V has an automatic program to heat up the screed according to a pre-defined sequence with 18 days.

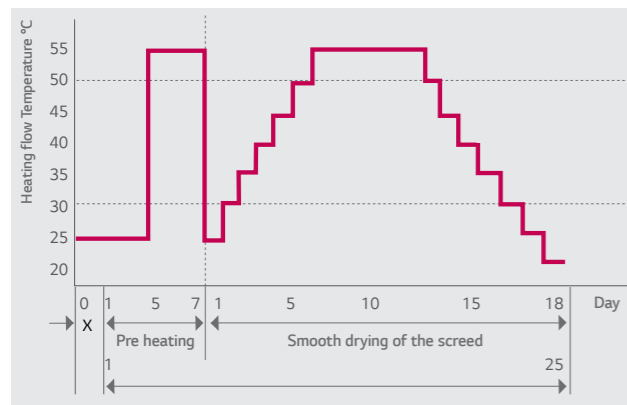

Notice : Some functions are not applied to the split type.

Extended Piping Length and Elevation

Through the BLDC inverter technology, it is possible to design a system with world-class longer piping length and elevation difference. With this feature, more efficient design & flexible installation is allowed.

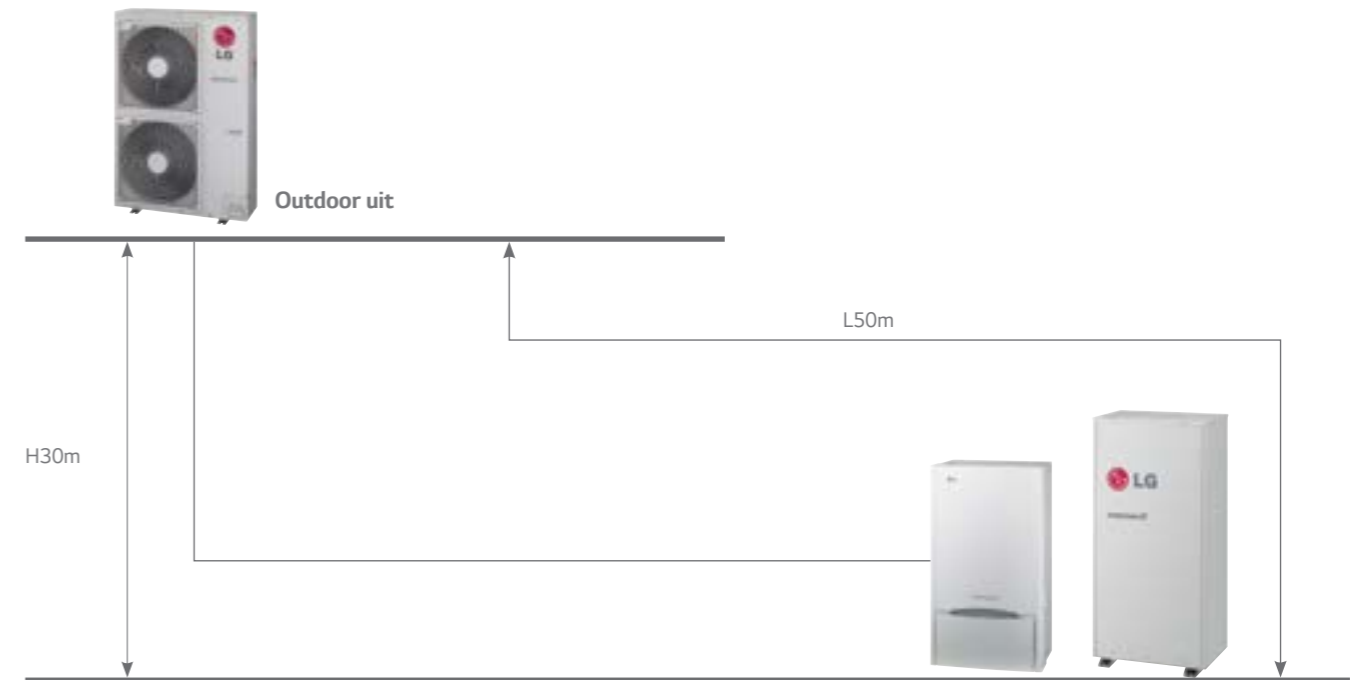

*Split type for mid. & high temp. model

Easy Service

Easy and efficient installation & service of outdoor unit will provide the comfort for installers.

- Compact Design & Ez SVC
 - Remove 3 pieces of screw for SVC
 - Front panel removal system

- Easy access
 - Easily accessible SVC parts like compressor, water pump, etc.

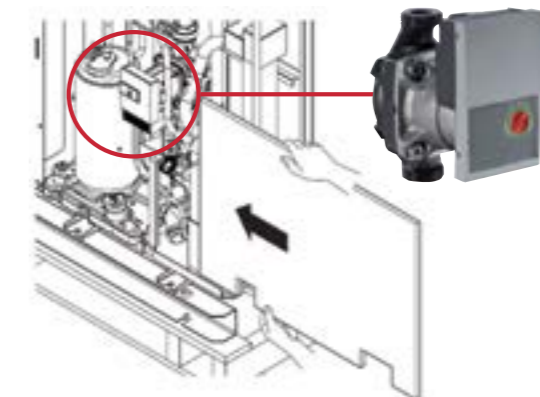
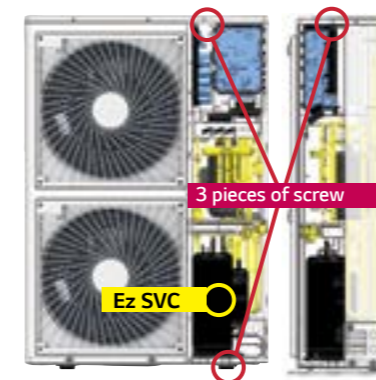

FLEXIBLE APPLICATIONS

Hybrid System with Boiler Backup

Dry Contact will expand the heating system network into conventional boiler.

- **Monobloc + Boiler Hybrid**

MONOBLOC + DOMESTIC HOT WATER + BOILER + RADIATORS + HOT WATER

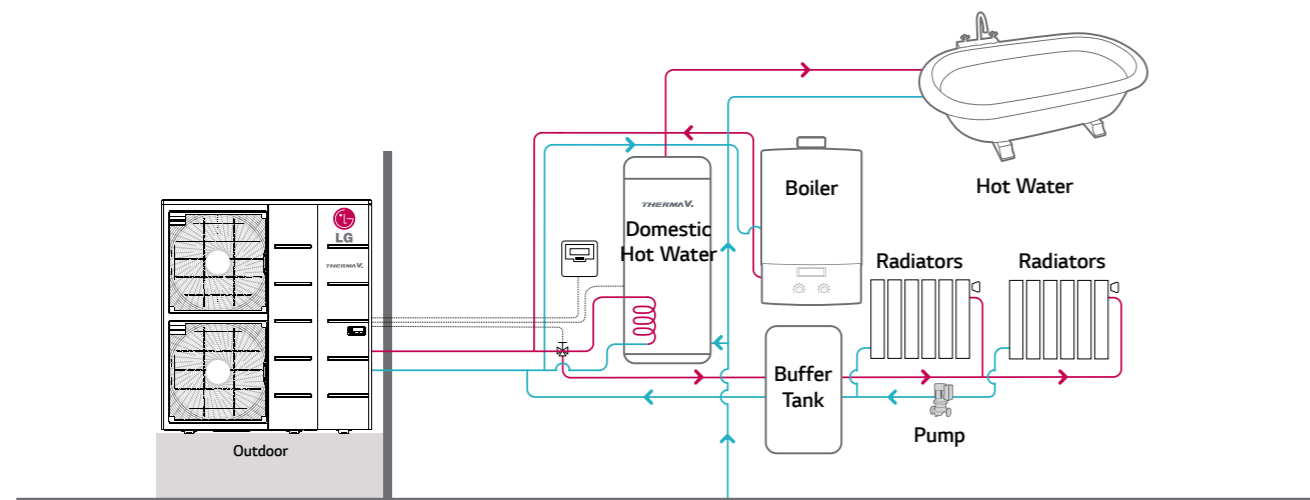

- **Split + Boiler Hybrid**

SPLIT + DOMESTIC HOT WATER + BOILER + RADIATORS + HOT WATER

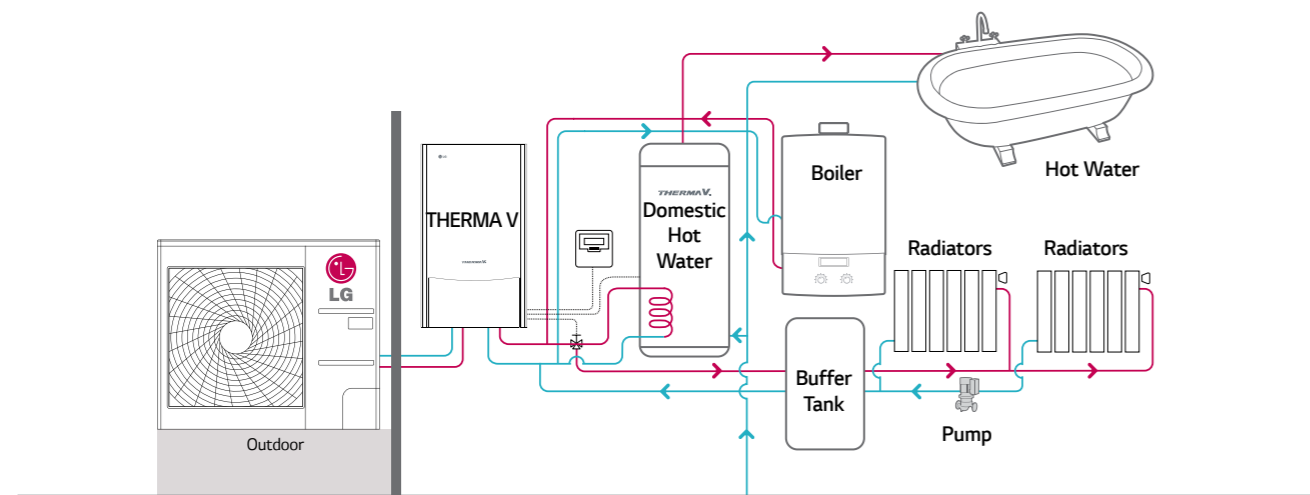

Linkage with Solar Thermal kit

THERMA V can be linked with solar kit as an accessory, when solar pumps works, it will be displayed in the remote controller.

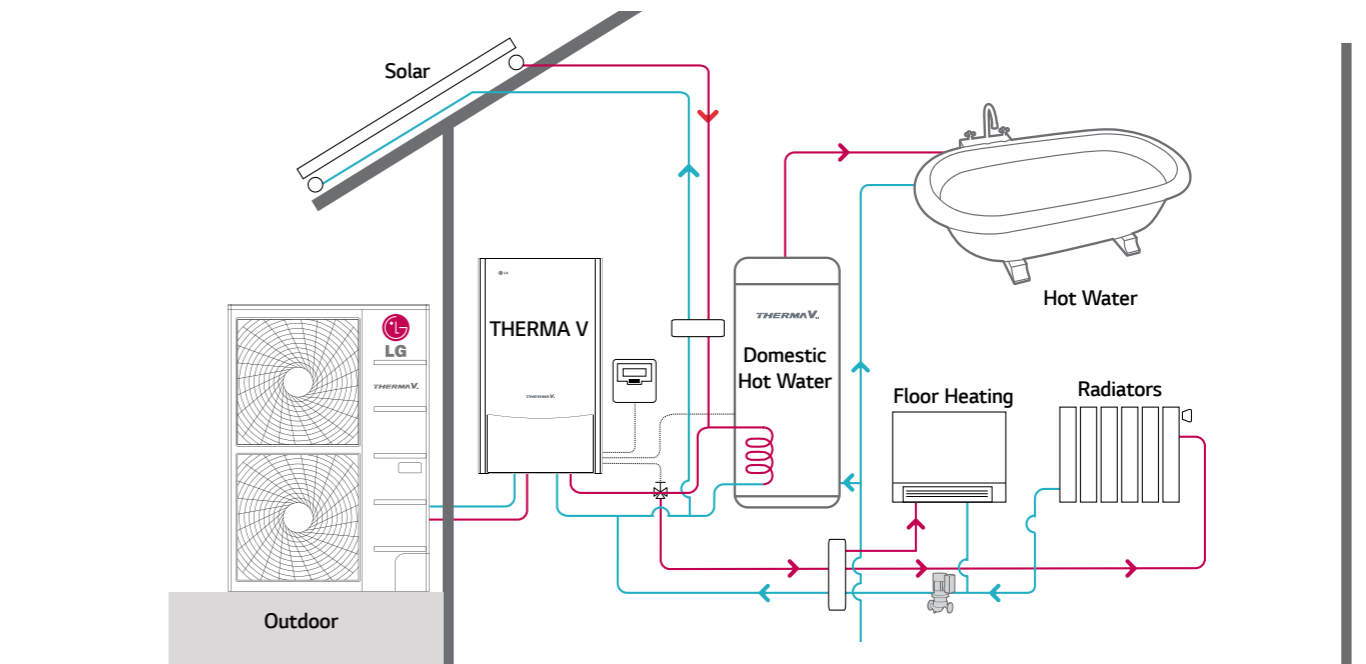

FLEXIBLE APPLICATION

SPLIT TYPE

Application 1

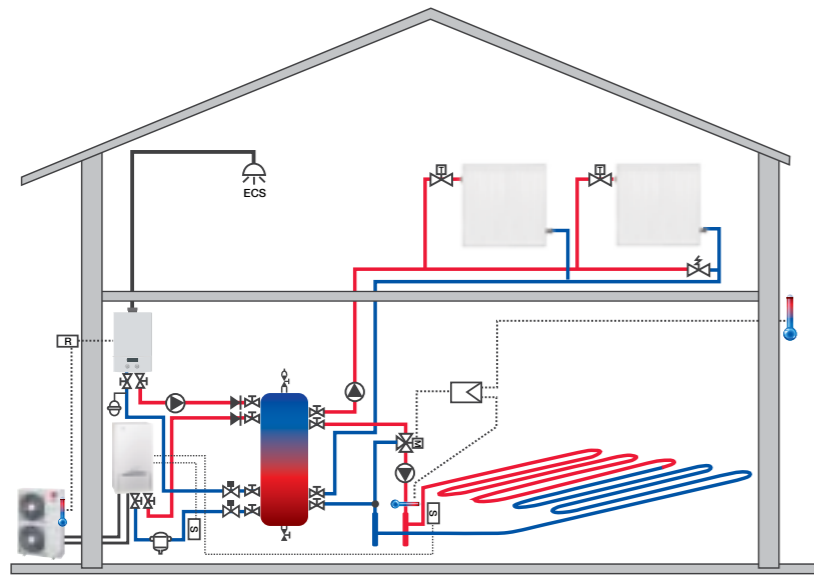

	Temperature Sensor
	Security Thermostat
	Regulator
	Regulation Thermostat
	Water Pump
	Check Valve
	Shut-Off Valve
	Motorized 3 ways Valve
	Relief Valve
	Motorized 2 ways Valve
	By pass Valve
	Decantation tank
	Expansion tank

> Bivalent operation mode

> Operation system

- Underfloor heating
- Low temperature radiators
- Domestic hot water THERMA V + Previous boiler system (option)

Application 3

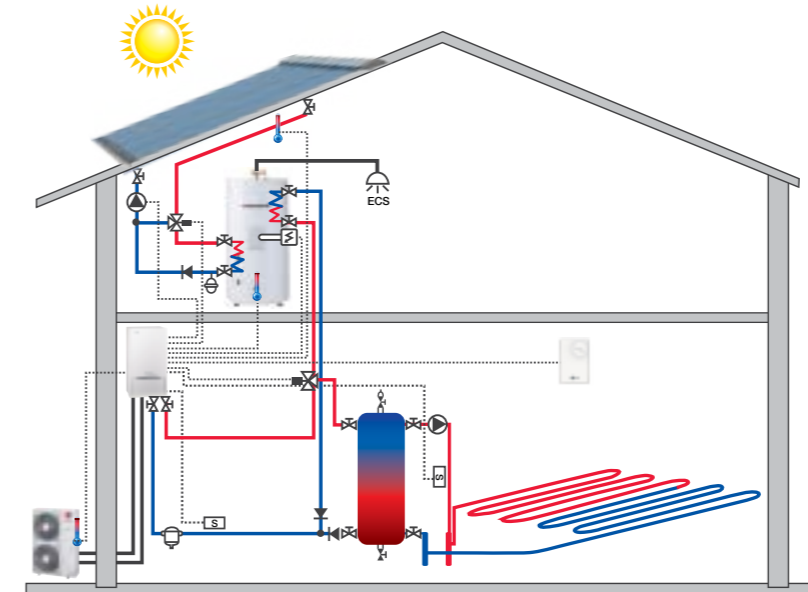

	Controller
	Temperature Sensor
	Electric Heater
	Security Thermostat
	Water Pump
	Check Valve
	Shut-Off Valve
	Motorized 2 ways Valve
	Decantation tank
	Expansion tank

> Bivalent operation mode

> Operation system

- Underfloor heating
- Domestic hot water THERMA V + Solar panels(option)

Application 2

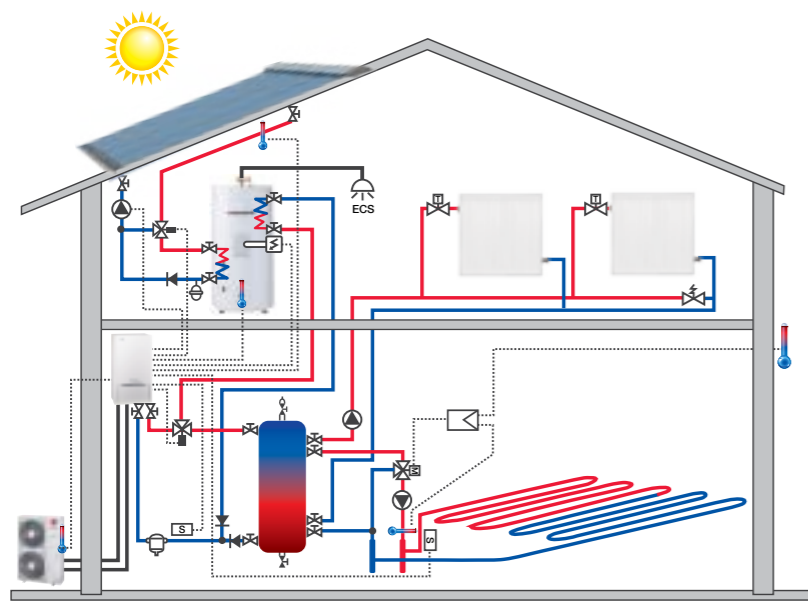

	Temperature Sensor
	Security Thermostat
	Regulator
	Electric Heater
	Water Pump
	Check Valve
	Shut-Off Valve
	Motorized 2 ways Valve
	Motorized 3 ways Valve
	Relief Valve
	By pass Valve
	Decantation tank
	Expansion tank

> Bivalent operation mode

> Operation system

- Underfloor heating
- Low temperature radiators
- Domestic hot water
- THERMA V + Solar panels(option)

Application 4

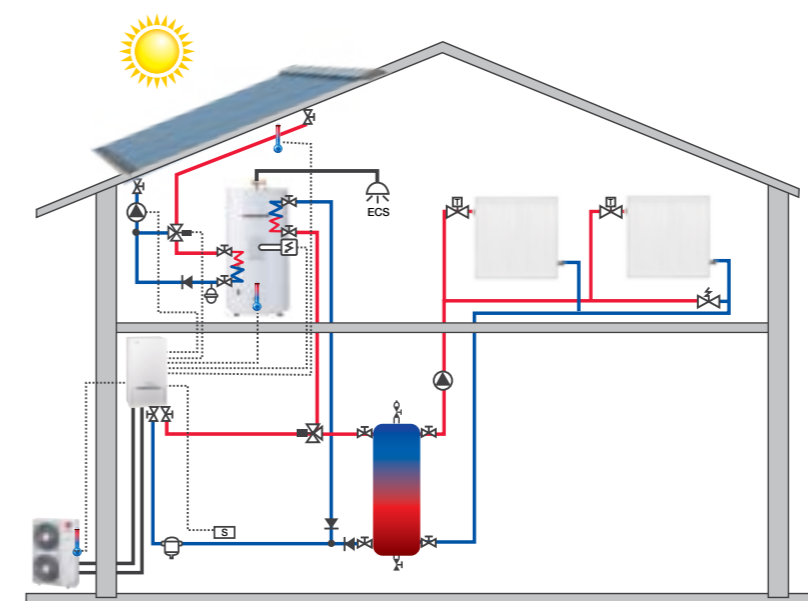

	Temperature Sensor
	Electric Heater
	Security Thermostat
	Water Pump
	Check Valve
	Shut-Off Valve
	By pass Valve
	Motorized 2 ways Valve
	Relief Valve
	Decantation tank
	Expansion tank

> Bivalent operation mode

> Operation system

- Low temperature radiators
- Domestic hot water THERMA V + Solar panels

FLEXIBLE APPLICATION MONOBLOC TYPE

Application 1

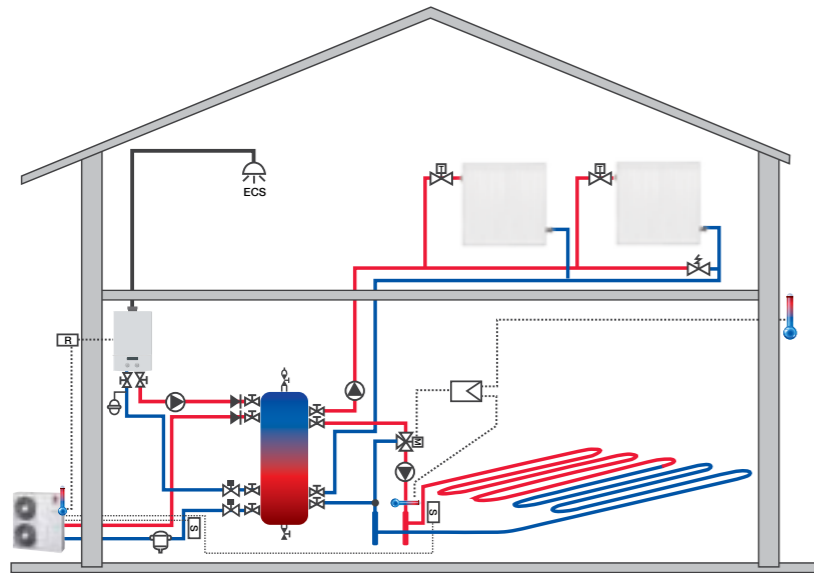

	Temperature Sensor
	Security Thermostat
	Regulator
	Regulation Thermostat
	Water Pump
	Check Valve
	Shut-Off Valve
	Motorized 3 ways Valve
	Relief Valve
	Motorized 2 ways Valve
	By pass Valve
	Decantation tank
	Expansion tank

> Bivalent operation mode

> Operation system

- Underfloor heating
- Low temperature radiators
- Domestic hot water THERMA V + Previous boiler system (option)

Application 2

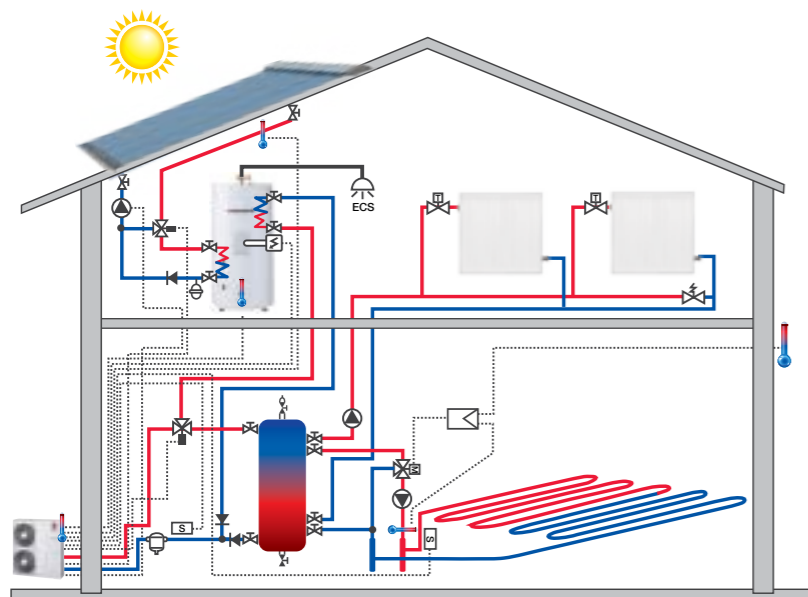

	Temperature Sensor
	Security Thermostat
	Regulator
	Electric Heater
	Water Pump
	Check Valve
	Shut-Off Valve
	Motorized 2 ways Valve
	Motorized 3 ways Valve
	Relief Valve
	By pass Valve
	Decantation tank
	Expansion tank

> Bivalent operation mode

> Operation system

- Underfloor heating
- Low temperature radiators
- Domestic hot water
- THERMA V + Solar panels(option)

Application 3

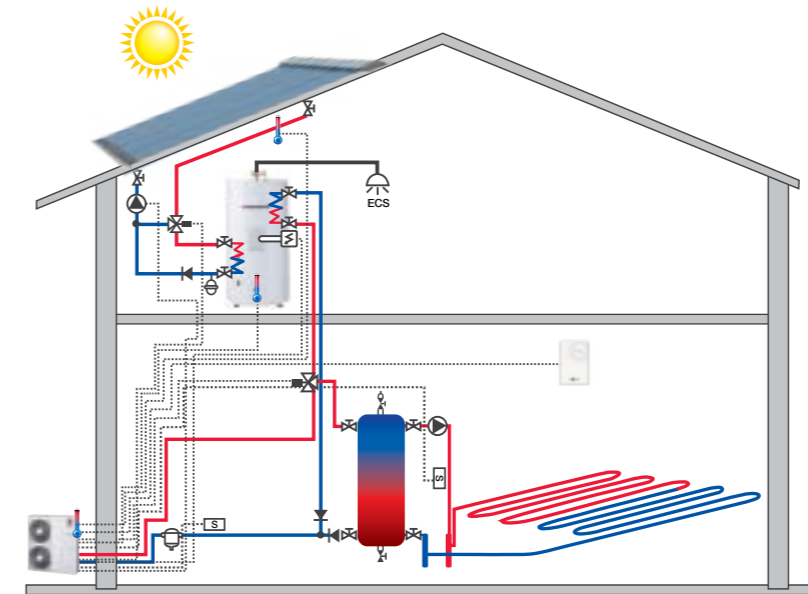

	Controller
	Temperature Sensor
	Electric Heater
	Security Thermostat
	Water Pump
	Check Valve
	Shut-Off Valve
	Motorized 2 ways Valve
	Decantation tank
	Expansion tank

> Bivalent operation mode

> Operation system

- Underfloor heating
- Domestic hot water THERMA V + Solar panels(option)

Application 4

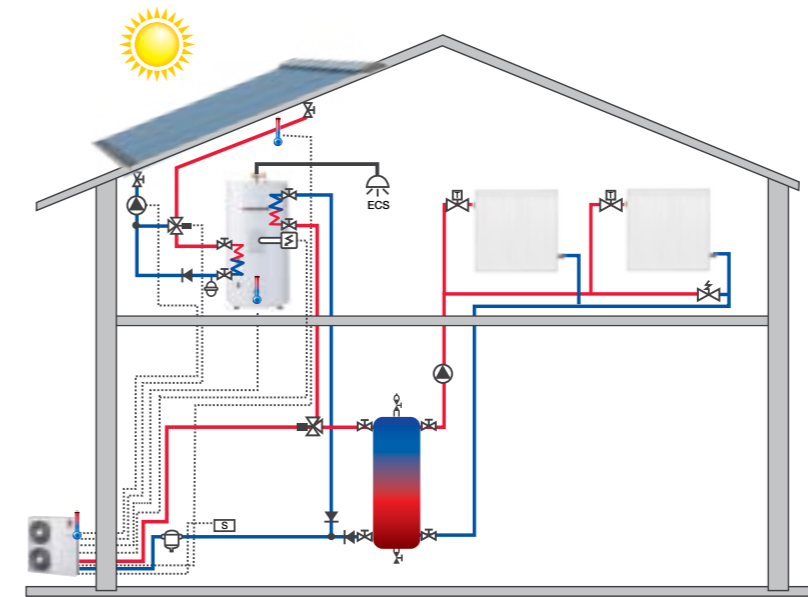

	Temperature Sensor
	Electric Heater
	Security Thermostat
	Water Pump
	Check Valve
	Shut-Off Valve
	By pass Valve
	Motorized 2 ways Valve
	Relief Valve
	Decantation tank
	Expansion tank

> Bivalent operation mode

> Operation system

- Low temperature radiators
- Domestic hot water THERMA V + Solar panels

THERMA V HIGH TEMPERATURE

HIGH TEMPERATURE TYPE (1Ø 220V~240V)

Cycle Diagram

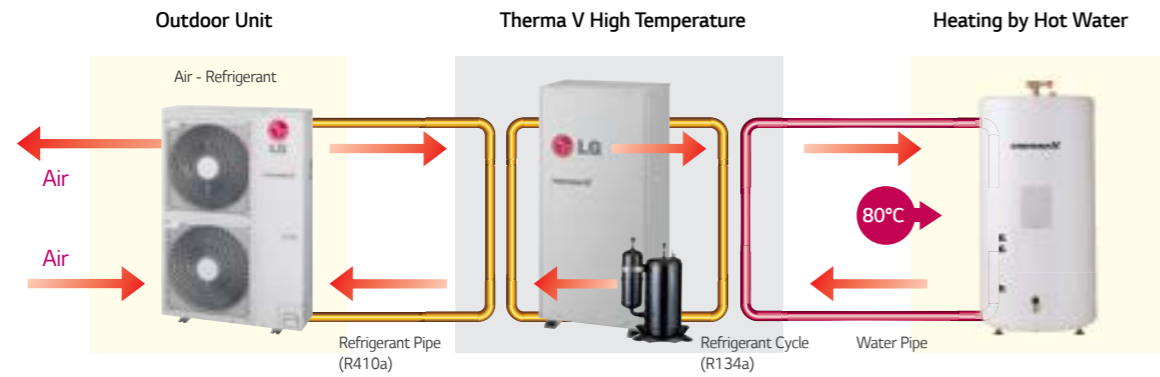

Enhanced Efficiency & Performance

Therma V high temp. can produce Max. 80°C hot water with 3 times higher efficiency compare to fuel boiler

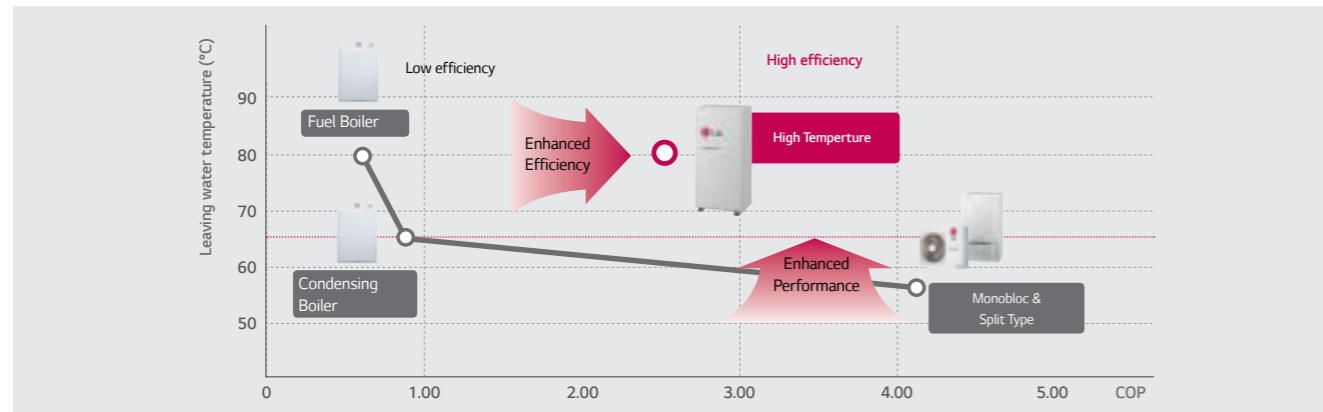

Cascade 2 Stage Compression Technology

Max. 80°C hot water can be generated through Cascade R410A to R134A BLDC compressor technology and applicable for existing old boiler heating system which demands hot water supply.

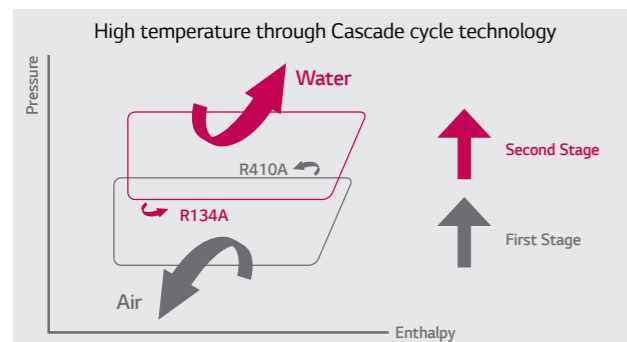

Quick Defrosting

Through R134A compressor controlling technology, necessary time for defrost operation has been minimized effectively. (LG Patent)

Time	2 min.	4 min.	6 min.	8 min.
Standard Defrosting	[Image]	[Image]	[Image]	[Image]
Hybrid Defrosting	[Image]	[Image]	[Image]	[Image]

Split		Unit	HU161H.U32
Outdoor Unit			
Power Supply		Ø / V / Hz	1/220-240/50
Capacity	Heating	kw	16.00
	Cooling	kw	-
Power Input	Heating	kw	6.13
	Cooling	kw	-
COP	Heating	W/W	2.61
EER	Cooling	W/W	-
Sound Pressure Level	Heating	dB(A)	53
	Cooling	dB(A)	-
Sound Power Level	Heating	dB(A)	-
	Cooling	dB(A)	-
Operation Range	Heating(Outdoor Temperature)	°C DB	-15~35
	Domestic Hot water	°C DB	25~80
Dimensions	Unit(W x H x D)	mm	950x1,380x330
Weight	Unit	kg	105
Compressor	Type	-	Hermetic Motor
	Refrigerant	Type	R410A
Piping Length	Minimum	m	5
	Standard	m	7.5
	Maximum	m	50
Piping Level Difference	Maximum	m	30

Split		Unit	HN1610H.NK2
Indoor Unit			
Power Supply		Ø / V / Hz	1/220-240/50
Dimensions	Unit(W x H x D)	mm	520x1,080x330
Weight	Unit	kg	94
Compressor	Type	-	Twin Rotary Inverter
Refrigerant	Type	-	R134A
Heat Exchanger	Type	-	Blazed Plate HEX
Sound Pressure Level	Heating	dB(A)	43

Note :
 1. Capacities and power inputs are based on the following conditions:
 - Heating Condition : Inlet / Outlet Water Temperature 55°C / 65°C, Outdoor Air Temperature 7°C DB / 6°C WB
 - Piping Length : Interconnected Pipe Length = 7.5m
 - Difference Limit of Elevation (Outdoor - Indoor Unit) is Zero.
 2. The specification may be subject to change without prior notice for purpose of improvement.

MONOBLOC TYPE (1Ø 220V~240V)



Monobloc		Unit	HM03M1.U42	HM051M.U42	HM071M.U42	HM091M.U32
Power Supply		Ø/V/Hz	1/220-240/50	1/220-240/50	1/220-240/50	1/220-240/50
Dimensions	Unit(W x H x D)	mm	950x834x330	1,239x907x390	1,239x907x390	1,239x907x390
Weight	Unit	kg	60	99	99	99
Capacity	Heating	kW	3.00	4.99	7.00	9.00
	Cooling	kW	-	4.99	7.00	9.00
Power Input	Heating	kW	0.73	1.13	1.63	2.20
	Cooling	kW	-	1.38	2.00	2.65
COP	Heating	W/W	4.10	4.40	4.30	4.10
EER	Cooling	W/W	-	3.61	3.50	3.40
Sound Pressure Level	Heating	dB(A)	47	51	52	52
	Cooling	dB(A)	-	50	52	52
Sound Power Level	Cooling	dB(A)	-	63	65	67
Operation Range (Min.-Max.) Outdoor Temperature	Heating	°C DB	-20~30	-20~30	-20~30	-20~30
	Cooling	°C	5~48	5~48	5~48	5~48
Operation Range (Min.-Max.) Leaving Water Temperature	Heating (Radiator)	°C	15~57	15~57	15~57	15~57
	Heating (Under floor)	°C	15~57	15~57	15~57	15~57
	Cooling (Fan coil unit)	°C	-	6~30	6~30	6~30
	Cooling (Under floor)	°C	-	16~30	16~30	16~30
Compressor	Type		Hermetic Motor	Hermetic Motor	Hermetic Motor	Hermetic Motor
Refrigerant	Type		R410A	R410A	R410A	R410A
Heat Exchanger	Type	-	Brazed Plate HEX	Brazed Plate HEX	Brazed Plate HEX	Brazed Plate HEX
Pump	Type	-	Canned type for hot water circulation			
Electric Heater	Number of Heating Coil	EA	-	2+2	2+2	2+2

Note :
 1. Capacities and power inputs are based on the following conditions:
 - Heating Condition : Inlet / Outlet Water Temperature 30°C / 35°C, Outdoor Air Temperature 7°C DB / 6°C WB
 - Cooling Condition : Inlet / Outlet Water Temperature 23°C / 18°C, Outdoor Air Temperature 35°C DB / 24°C WB
 2. The specification may be subject to change without prior notice for purpose of improvement.

Monobloc		Unit	HM121M.U32	HM141M.U32	HM161M.U32
Power Supply		Ø/V/Hz	1/220-240/50	1/220-240/50	1/220-240/50
Dimensions	Unit(W x H x D)	mm	1,239x1,450x390	1,239x1,450x390	1,239x1,450x390
Weight	Unit	kg	141	141	141
Capacity	Heating	kW	12.00	14.00	16.00
	Cooling	kW	14.50	15.50	16.10
Power Input	Heating	kW	2.67	3.15	3.81
	Cooling	kW	4.00	4.69	5.07
COP	Heating	W/W	4.49	4.44	4.20
EER	Cooling	W/W	3.63	3.30	3.18
Sound Pressure Level	Heating	dB(A)	53	53	53
	Cooling	dB(A)	54	54	54
Sound Power Level	Cooling	dB(A)	68	68	68
Operation Range (Min.-Max.) Outdoor Temperature	Heating	°C DB	-20~30	-20~30	-20~30
	Cooling	°C	5~48	5~48	5~48
Operation Range (Min.-Max.) Leaving Water Temperature	Heating(Radiator)	°C	15~57	15~57	15~57
	Heating(Under floor)	°C	15~57	15~57	15~57
	Cooling(Fan coil unit)	°C	6~30	6~30	6~30
	Cooling(Under floor)	°C	16~30	16~30	16~30
Compressor	Type		Hermetic Motor	Hermetic Motor	Hermetic Motor
Refrigerant	Type		R410A	R410A	R410A
Heat Exchanger	Type	-	Brazed Plate HEX	Brazed Plate HEX	Brazed Plate HEX
Pump	Type	-	Canned type for hot water circulation		
Electric Heater	Number of Heating Coil	EA	3+3	3+3	3+3

Note :
 1. Capacities and power inputs are based on the following conditions:
 - Heating Condition : Inlet / Outlet Water Temperature 30°C / 35°C, Outdoor Air Temperature 7°C DB / 6°C WB
 - Cooling Condition : Inlet / Outlet Water Temperature 23°C / 18°C, Outdoor Air Temperature 35°C DB / 24°C WB
 2. The specification may be subject to change without prior notice for purpose of improvement.

MONOBLOC TYPE (3Ø 380V~415V)



Monobloc	Unit	HM123M.U32	HM143M.U32
Power Supply	Ø/V/Hz	3/380-415/50	3/380-415/50
Dimensions	Unit(W x H x D)	mm	1,239x1,450x390
Weight	Unit	kg	141
Capacity	Heating	kW	12.00
	Cooling	kW	14.50
Power Input	Heating	kW	2.67
	Cooling	kW	4.00
COP	Heating	W/W	4.49
EER	Cooling	W/W	3.63
Sound Pressure Level	Heating	dB(A)	53
	Cooling	dB(A)	54
Sound Power Level	Cooling	dB(A)	68
Operation Range (Min.-Max.) Outdoor Temperature	Heating	°C DB	-20~30
	Cooling	°C	5~48
Operation Range (Min.-Max.) Leaving Water Temperature	Heating (Radiator)	°C	15~57
	Heating (Under floor)	°C	15~57
	Cooling (Fan coil unit)	°C	6~30
	Cooling (Under floor)	°C	16~30
Compressor	Type		Hermetic Motor
Refrigerant	Type		R410A
Heat Exchanger	Type	-	Brazed Plate HEX
Pump	Type	-	Canned type for hot water circulation
Electric Heater	Number of Heating Coil	EA	2+2+2

Note :

- Capacities and power inputs are based on the following conditions:
 - Heating Condition : Inlet / Outlet Water Temperature 30°C / 35°C, Outdoor Air Temperature 7°C DB / 6°C WB
 - Cooling Condition : Inlet / Outlet Water Temperature 23°C / 18°C, Outdoor Air Temperature 35°C DB / 24°C WB
- The specification may be subject to change without prior notice for purpose of improvement.



Monobloc	Unit	HM163M.U32
Power Supply	Ø/V/Hz	3/380-415/50
Dimensions	Unit(W x H x D)	mm
Weight	Unit	kg
Capacity	Heating	kW
	Cooling	kW
Power Input	Heating	kW
	Cooling	kW
COP	Heating	W/W
EER	Cooling	W/W
Sound Pressure Level	Heating	dB(A)
	Cooling	dB(A)
Sound Power Level	Cooling	dB(A)
Operation Range (Min.-Max.) Outdoor Temperature	Heating	°C DB
	Cooling	°C
Operation Range (Min.-Max.) Leaving Water Temperature	Heating (Radiator)	°C
	Heating (Under floor)	°C
	Cooling (Fan coil unit)	°C
	Cooling (Under floor)	°C
Compressor	Type	Hermetic Motor
Refrigerant	Type	R410A
Heat Exchanger	Type	-
Pump	Type	-
Electric Heater	Number of Heating Coil	EA

Note :

- Capacities and power inputs are based on the following conditions:
 - Heating Condition : Inlet / Outlet Water Temperature 30°C / 35°C, Outdoor Air Temperature 7°C DB / 6°C WB
 - Cooling Condition : Inlet / Outlet Water Temperature 23°C / 18°C, Outdoor Air Temperature 35°C DB / 24°C WB
- The specification may be subject to change without prior notice for purpose of improvement.

SPLIT INDOOR UNIT (1Ø 230V, 3Ø 400V)



Hydrokit _ Indoor Unit			HN0914. NK1	*HN0916. NK1	*HN0926. NK1	*HN0936. NK1	HN1616. NK1	HN1626. NK1	HN1636. NK1	*HN1629. NK1	HN1639. NK1
Combined Outdoor Unit			HU091.U41 - 1Ø 230V				HU121.U31 - 1Ø 230V HU141.U31 - 1Ø 230V HU161.U31 - 1Ø 230V HU123.U31 - 3Ø 400V HU143.U31 - 3Ø 400V HU163.U31 - 3Ø 400V				
Electric Heater	Power Supply	ø/V/Hz	1ø/220-240V/50Hz	1ø/220-240V/50Hz	3ø/380-415V/50Hz	1ø/220-240V/50Hz	1ø/220-240V/50Hz	3ø/220V/50Hz	3ø/380-415V/50Hz	3ø/220V/50Hz	3ø/380-415V/50Hz
Heater	Capacity	kW	4	6			6			9	
Dimension	W*H*D	mm	490*850*315				490*850*315				
Weight		kg	48				54.5				
Noise Level at 1 meter		dB(A)	28				28				
Leaving Water Temperature	Heating	°C	15-55				15-55				
	Cooling	°C	6-30				6-30				
Water Pump	Max Power Input	Watt	135				205				
	Minimum Water Flow Rate	LPM	15				15				
Max. Head		meter	6				7				
Expansion Tank		liter	8				8				

SPLIT OUTDOOR UNIT (1Ø 230V)



Outdoor Unit			HU091. U41	
Combined Hydrokit			HN0916. NK1 HN0926. NK1 HN0936. NK1 HN0914. NK1	
Power Supply	ø/ V / Hz		1ø / 220-240V / 50Hz	
Nominal Capacity	Heating(A10/W35)	kW	9.71	
	Heating(A7/W35)	kW	9	
	Heating(A2/W35)	kW	6.87	
	Heating(A-7/W35)	kW	8.61	
	Cooling(A35/W18)	kW	9.00	
Nominal Input	Heating(A10/W35)	kW	2.2	
	Heating(A7/W35)	kW	2.2	
	Heating(A2/W35)	kW	2.07	
	Heating(A-7/W35)	kW	3.19	
	Cooling(A35/W18)	kW	2.65	
COP	Heating(A10/W35)	WW	4.41	
	Heating(A7/W35)	WW	4.09	
	Heating(A2/W35)	WW	3.32	
	Heating(A-7/W35)	WW	2.70	
EER	Cooling(A35/W18)	WW	3.40	
Sound pressure level	Heating	dB(A)	52	
	Cooling	dB(A)	52	
Dimension	W*H*D	mm	950*834*330	
Weight		kg	64	
Refrigerant (R410A)	Pre-charged amount	g	1,900	
	Pipe Diameter(Liquid/Gas)	inch	3/8, 5/8	

SPLIT OUTDOOR UNIT (1Ø 230V)



Outdoor Unit			HU121. U31	HU141. U31	HU161. U31
Combined Hydrokit			HN1616. NK1 HN1626. NK1 HN1636. NK1 HN1629. NK1 HN1639. NK1		
Power Supply					
Nominal Capacity	Heating(A10/W35)	kW	13.32	14.94	16.93
	Heating(A7/W35)	kW	12	14	16
	Heating(A2/W35)	kW	9.4	10.69	11.9
	Heating(A-7/W35)	kW	11.48	13.11	14.8
	Cooling(A35/W18)	kW	14.00	14.00	14.00
Nominal Input	Heating(A10/W35)	kW	2.99	3.39	3.87
	Heating(A7/W35)	kW	2.67	3.15	3.81
	Heating(A2/W35)	kW	2.8	3.22	3.62
	Heating(A-7/W35)	kW	4.16	4.85	5.61
	Cooling(A35/W18)	kW	4.40	4.40	4.40
COP	Heating(A10/W35)	WW	4.45	4.41	4.37
	Heating(A7/W35)	WW	4.49	4.44	4.20
	Heating(A2/W35)	WW	3.36	3.32	3.29
	Heating(A-7/W35)	WW	2.76	2.70	2.64
EER	Cooling(A35/W18)	WW	3.18	3.18	3.18
Sound pressure level	Heating	dBA	53		
	Cooling	dBA	54		
Dimension	W*H*D	mm	950*1,380*330		
Weight		kg	105		
Refrigerant (R410A)	Pre-charged amount	g	2,980		
	Pipe Diameter(Liquid/Gas)	inch	3/8, 5/8		

SPLIT OUTDOOR UNIT (3Ø 400V)



Outdoor Unit			HU123. U31	HU143. U31	HU163. U31
Combined Hydrokit			HN1616. NK1 HN1626. NK1 HN1636. NK1 HN1629. NK1 HN1639. NK1		
Power Supply					
Nominal Capacity	Heating(A10/W35)	kW	13.25	15.06	17.34
	Heating(A7/W35)	kW	12	14	16
	Heating(A2/W35)	kW	9.46	10.89	12.22
	Heating(A-7/W35)	kW	11.66	12.72	14.92
	Cooling(A35/W18)	kW	14.60	15.50	16.80
Nominal Input	Heating(A10/W35)	kW	3.02	3.49	4.1
	Heating(A7/W35)	kW	2.72	3.24	3.81
	Heating(A2/W35)	kW	2.83	3.28	3.82
	Heating(A-7/W35)	kW	4.31	4.98	5.95
	Cooling(A35/W18)	kW	4.02	4.65	5.09
COP	Heating(A10/W35)	W/W	4.39	4.32	4.23
	Heating(A7/W35)	W/W	4.41	4.32	4.20
	Heating(A2/W35)	W/W	3.34	3.32	3.20
	Heating(A-7/W35)	W/W	2.71	2.55	2.51
EER	Cooling(A35/W18)	W/W	3.63	3.33	3.30
Sound pressure level	Heating	dBA	53		
	Cooling	dBA	54		
Dimension	W*H*D	mm	950*1,380*330		
Weight		kg	105		
Refrigerant (R410A)	Pre-charged amount	g	2,980		
	Pipe Diameter(Liquid/Gas)	inch	3/8, 5/8		

DOMESTIC HOT WATER TANK



Domestic Hot Water Tank – Single Coil

DOMESTIC HOT WATER TANK		LGRTV200E	LGRTV300E
GENERAL CHARACTERISTICS			
Water Volume	L	198	287
Diameter	mm	580	580
Height	mm	1230	1680
Empty Weight	kg	45	59
Tank – Materials		Stainless steel	Stainless steel
Outer Skin – Materials		Paint Epoxy	Paint Epoxy
Color – White RA		White NC	White NC
CHARACTERISTICS OF ELECTRICAL BACK-UP			
Additional Electric Heater	kW	3	3
Adjustable Thermostat	°C	60 - 90	60 - 90
CHARACTERISTICS OF EXCHANGER			
Exchanger Type		Single	Single
Material Exchanger		LDX 2101 – Stainless steel	LDX 2101 – Stainless steel
Maximum Water Temperature	°C	80	80
HYDRAULIC CONNECTIONS – HEAT PUMP			
THERMA V Entry	mm	25	25
THERMA V Exit	mm	25	25
HYDRAULIC CONNECTIONS – DOMESTIC HOT WATER TANK			
City Water Entry	mm	22	22
Hot water Exit	mm	22	22
ELECTRIC CONNECTION			
Supply	ø/V/Hz	1ø/220-240V 50Hz	1ø/220-240V 50Hz
MANDATORY OPTIONAL ACCESSORIES			
Sanitary Water Tank Installation Kit		PHLTA	PHLTA

Domestic Hot Water Tank – Double Coil

DOMESTIC HOT WATER TANK		LGRTV200VE	LGRTV300VE
GENERAL CHARACTERISTICS			
Water Volume	L	198	287
Diameter	mm	580	580
Height	mm	1230	1680
Empty Weight	kg	50	64
Tank – Materials		Stainless steel	Stainless steel
Outer Skin – Materials		Paint Epoxy	Paint Epoxy
Color – White RAL		White NC	White NC
CHARACTERISTICS OF ELECTRICAL BACK-UP			
Additional Electric Heater	kW	3	3
Adjustable Thermostat	°C	60 - 90	60 - 90
CHARACTERISTICS OF EXCHANGER			
Exchanger Type		Double	Double
Material Exchanger		LDX 2101 – Stainless steel	LDX 2101 – Stainless steel
Maximum Water Temperature	°C	80 (With an Heat Pump)	80 (With an Heat Pump)
HYDRAULIC CONNECTIONS – HEAT PUMP			
THERMA V Entry	mm	25	25
THERMA V Exit	mm	25	25
HYDRAULIC CONNECTIONS – DOMESTIC HOT WATER TANK			
City Water Entry	mm	22	22
Hot water Exit	mm	22	22
ELECTRIC CONNECTION			
Supply	ø/V/Hz	1ø/220-240V 50Hz	1ø/220-240V 50Hz
MANDATORY OPTIONAL ACCESSORIES			
Domestic Hot Water Tank Installation Kit		PHLTA	PHLTA

Domestic Hot Water Tank - Single Coil

LGRTV200E	198 LITERS
LGRTV300E	287 LITERS



Domestic Hot Water Tank - Double Coil

LGRTV200VE	198 LITERS
LGRTV300VE	287 LITERS



Solar Thermal Collectors

For better performance and energy saving, it is possible to combine the THERMA V heat pump & solar thermal collectors.



DOMESTIC HOT WATER TANK KIT

- PHLTA (1Φ)
- PHLTC (3Φ)
- PHLTB



* The sensor (PHRSTAD) can be purchased separately in case of using other brand's Domestic tank.

Features

Easy to install the domestic hot water for monobloc. There is a MCCB to protect the product.
 Dimension(mm) (HxWxD) : 250x170x110
 Weight(kg) : 2.1

To extend THERMA V functionality in generating domestic hot water.

※To be installed inside THERMA V indoor unit.

Application

Components : THERMA V system, PHLTA, PHLTC, and field-supplied items.

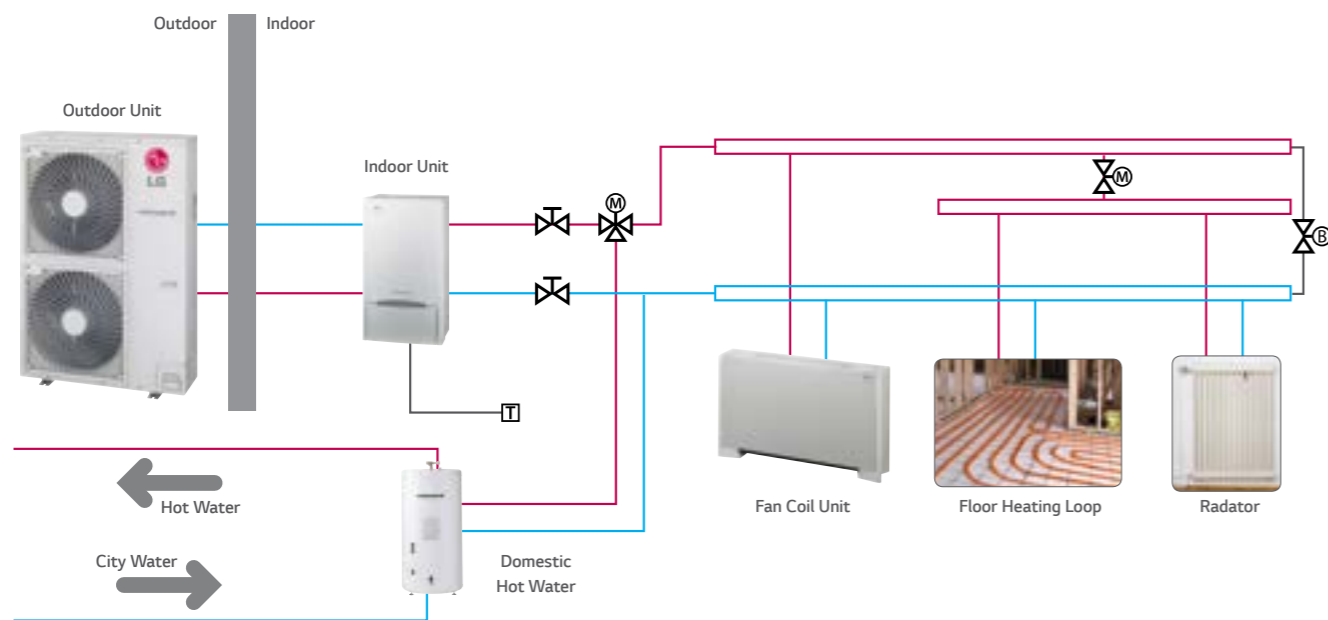

SOLAR THERMAL KIT

- PHLLA



Features

To interface solar-thermal system with THERMA V and double coil Domestic tank.
 Installed at the water pipe, between Domestic tank and solar-thermal system.
 Dimension(mm) (HxWxD) : 110x55x22

Application

Components : THERMA V system, PHLTA, PHLTC, and field-supplied items.

